

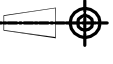

75cl ∅ 50mm 

NAME	DATE	REVISIONS	MOLD NO.			A3		DRUJBA Glassworks S.A. A Member of Yioula Group
MD	05/09	Weight was 500gr	FINISH	FIN 035				
			CAP. BRIMF.	770 ± 10ml	MACHINE			BOTTLE
			CAP. FILLPT.	750 ± 10ml	DATE	28/05/2009		75cl DORICA
			FILL LINE	50 mm	DRAWN	Dimov		CAT.No & DWG No
			WEIGHT	470gr	CHECKED	Angelov		6008035
			COLOR		CONFIRMED			SHEET: 1/1 SCALE: 1:1